

BOLT PEDESTAL

The BOLT arm has super-fast acceleration, going from standstill to high-speed and back in fractions of seconds. This gives it the ability to follow falling objects whilst capturing images in crisp focus that would be impossible by any other method. The BOLT is the perfect rig for high-speed shoots.

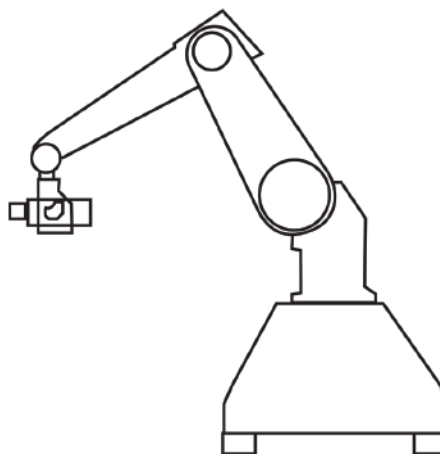

Access/set up

The BOLT PEDESTAL weighs around 650kg and the counter weights 560kg. The set up takes approximately 45min when used with counter weights, or 1 hour when fixed to the floor.

The shorter the access ways and more even the set-up site, the quicker it is to set up the BOLT PEDESTAL.

The 'clear width' of the doors should be 1,90m tall and 150cm wide.

The BOLT PEDESTAL and its equipment is delivered on a 7.5-tonne truck (L7.50m, W2.50m, H3.40m).

Power supply

A separate power line for CEE 32 Amp connector is needed. Power connections to film lighting generators can be used without concern. They should supply at least 3000 VA-12kA.

Mounting cameras/lenses

Most film, video and digital cameras can be mounted onto the BOLT camera platform as long as they weigh less than 20 kg. For stability at high speeds it is still recommended to not use heavy camera and lenses. The head has 2 x 19mm mounts for rods. Steel rods are preferable over aluminium/carbon.

Special control cables are available to provide sync at different frame rates to ARRI Alexa and RED and PHANTOM camera models.

The lenses are fitted with motion controlled focus/zoom/iris motors and run by the BOLT PEDESTAL.

Triggers/SFX timing

The BOLT PEDESTAL can trigger external devices such as Solenoids, Cylinders, Motorized SFX systems via relays. This allows SFX timing to be connected to/triggered by the BOLT PEDESTAL.

Restrictions

The BOLT PEDESTAL is not sound-proof due to ventilation and the motor noises that it produces.

The BOLT PEDESTAL is not rain-proof since the electronics are built into the BOLT PEDESTAL directly. In such cases, the BOLT PEDESTAL can be shut down without losing any shoot data and covered on the spot until the rain has stopped. During light rain it is still possible to shoot if the BOLT PEDESTAL is partially covered.

On tough to reach locations it is recommended to have a prior set visit or location pictures.

The BOLT PEDESTAL can also be lifted with a crane.

Extras

There are additional motors or turntables available that can be used as an integrated part of the system. Further devices for externally controlling timing of SFX or custom pneumatic or motorized rigs, sliders and model movers can be provided on request. Connections or integration should be discussed before the shoot.

Specifications

Operating envelope

Maximum height (with level head)	2.37m
Lowest position	.0m
Maximum reach (from rotate centre)	2.0m

Rig performance

Axis	Range of travel	Maximum speeds
Rotate	+/- 160 degrees	240 degrees per sec
Lift	+/- 137 degrees	238 degrees per sec
Arm	+/- 150 degrees	313 degrees per sec
Pan	+/- 270 degrees	315 degrees per sec
Tilt	+ 120 degrees / -105 degrees	350 degrees per sec
Roll	+/- 270 degrees	870 degrees per sec

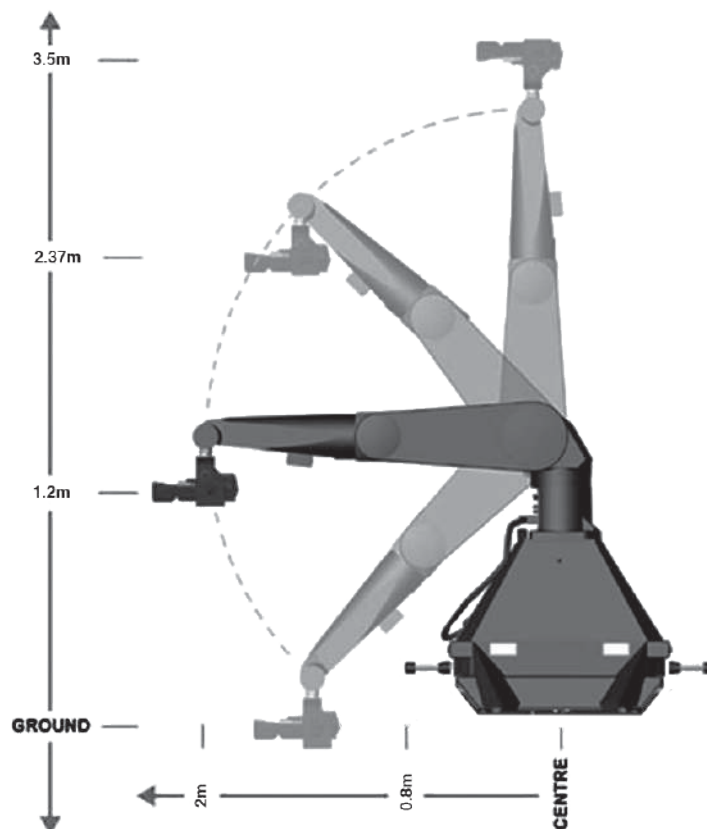

We reserve the right to change these specifications without notice. Spec dimensions dependent on type and size of camera used on the rig.